

MTT1

MASTER TURN TABLE

Tam Otomatik Döner Kafa Kumaş Serim Makinası
Fully Automatic Turn Table Fabric Spreading Machine

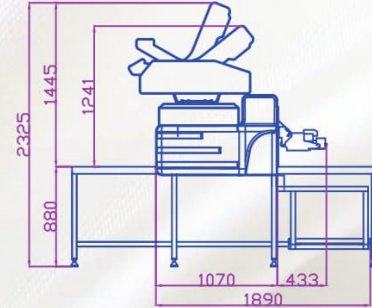
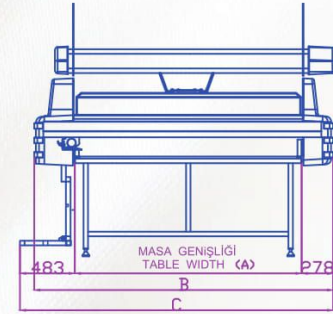

Teknik Özellikler		
Kesim aparatı ile maksimum serim yüksekliği	250 mm	
Maksimum zikzak serim yüksekliği	220 mm	
Maksimum kumaş top çapı	650 mm	
Maksimum kumaş top ağırlığı	250 Kg	
Maksimum serim hızı (m/dk.)	100 m	
Makine genişlikleri	1600 – 2000 mm	
Serim masası eni	1800 – 2200 mm	
Elektrik bilgileri	5 kW/220 V/50 Hz	

Technical Specifications		
Maximum spreading height with cutting device	250 mm	
Maximum zigzag spreading height	220 mm	
Maximum roll diameter	650 mm	
Maximum roll weight	250 Kg	
Maximum spreading speed (per minute)	100 m	
Fabric width	1600 – 2000 mm	
Table width	1800 – 2200 mm	
Electrical power	5 kW/220 V/50 Hz	

KUMAŞ GENİŞLİĞİ FABRIC WIDTH	A	B	C
1600	1800	2436	2561
1700	1900	2536	2661
1800	2000	2636	2761
1900	2100	2736	2861
2000	2200	2836	2961

MASTER TURN TABLE

Tam Otomatik Döner Kafa Kumaş Serim Makinası
Fully Automatic Turn Table Fabric Spreading Machine

MTT1



Cradle Feed sayesinde zor kumaşlar bile tansiyonsuz serim imkanı
Cradle Feed System Provides Tension-Free Spreading



ML1 Kumaş Yükleme Vinci
ML1 Fabric Lifting Device



Otomatik Kesim Aparatı
Automatic Cutting Device



SPREADING MODES

- ✓ Face up or face down
- ✓ Face to face with or without end catchers
- ✓ Face to face one way
- ✓ Multi length spreading

CRADLE FEED SYSTEM PROVIDES

- ✓ Tension-free spreading even difficult fabrics
- ✓ Electric cradle tilts for easy fabric roll loading/unloading
- ✓ Eliminates use of a fabric roll bar

SYSTEM FEATURES

- ✓ Electronic edge control responsive to variable speed
- ✓ Automatic stop with safety sensors in case of emergency
- ✓ Automatic pre-centering of material beginning during threading
- ✓ Variable speed control at forward/backward turns «Save Time»
- ✓ No cloth stop function
- ✓ Ply counter
- ✓ Programmable lay length and end allowance settings
- ✓ Four-wheel drive with wheels
- ✓ Turntable provides automatic rewinding, threading and positioning of material

ATTACHMENTS

- ✓ Zigzag equipment
- ✓ Rear catcher
- ✓ Movable front catcher
- ✓ Automatic cutting device
- ✓ ML1 Master Lift

250 KİLOYA KADAR YÖNLÜ KUMAŞLARIN DÖNER SEPET SİSTEMİ İLE KOLAY SERİMİ MJ1 MODELİ GİBİ GÜÇLÜ KONSTRİKSİYONU SAYESİNDE AĞIR TİP KUMAŞ SERİMİNİN DEDE KULLANILIR

- ✓ MJ1 Modeli gibi güçlü konstrüksiyonu sayesinde ağır tip kumaşların serimin dede kullanılır

PLC KONTROLLÜ DOKUNMATİK EKRAM

- ✓ Öğrenmesi ve eğitimi kolay basitleştirilmiş grafik ekran
- ✓ 50 Farklı kumaş serim ayarının hafızaya alınıp, gerektiğinde tekrar serimi için hafızadan çağırılması
- ✓ Türkçe, İngilizce ve isteğe göre diğer yabancı dil seçenekleri

SİSTEM ÖZELLİKLERİ

- ✓ Değişen hız duyarlı elektronik kenar kontrol sistemi
- ✓ Emniyet sensörleri ile tehlike anında otomatik durma
- ✓ Merdiven kumaş serim özelliği
- ✓ Serim başlangıcı sırasında kumaşın otomatik merkezlenmesi
- ✓ İleri, geri gidişlerde farklı hız seçenekleri, zamandan tasarruf
- ✓ Kumaş bitti otomatik durma özelliği
- ✓ Kat sayıcı
- ✓ Programlanabilir kat uzunluğu ve ilave kumaş verme ayarı
- ✓ 4x4 tahrik sistemi
- ✓ Döner kafa otomatik sarma, kumaş verme ve malzeme konumlandırma sağlar

CERTAIN SPREADS MODES SUPPORTED WEIGHTING UP 250 KGS (551LBS) WITH TURNTABLE - WITH ROBUST CONSTRUCTION, IT CAN BE USED FOR HEAVY FABRICS AS IF MJ1 MASTER JEANS

- ✓ With robust construction, it can be used for heavy fabric as if MJ1 Master Jean

LCD TOUCH SCREEN DISPLAY WITH PLC UNIT

- ✓ Simplified graphical display that is easy to learn and easy to train new operators
- ✓ Stores 50 different fabric set up files for quick retrieval to accelerate future spreading jobs
- ✓ Available in Turkish, English and any other foreign languages if requested

MULTI FUNCTION THROTTLE ENABLES THE OPERATOR TO CONTROL

- ✓ Threading/Rewinding of fabric
- ✓ Start/Stop of spreading with one hand

OPERATOR PLATFORM

- ✓ Allows operator to ride alongside the table