

MT1

MASTER Tam Otomatik Kumaş Serim Makinası Fully Automatic Fabric Spreading Machine

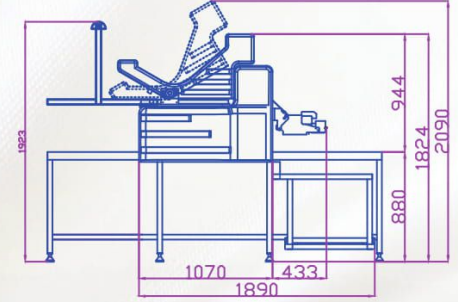
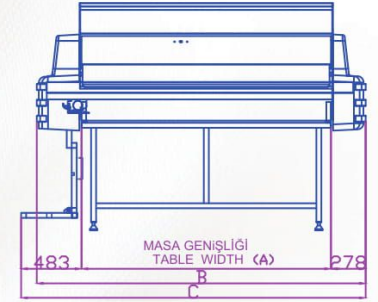

Teknik Özellikler

Kesim aparatı ile maksimum serim yüksekliği	250 mm
Maksimum zikzak serim yüksekliği	220 mm
Tüp aparatı ile maksimum serim yüksekliği	200 mm
Maksimum kumaş top çapı	650 mm
Maksimum kumaş top ağırlığı	200 Kg
Maksimum serim hızı (m/dk.)	100 m
Makine genişlikleri	1600 - 2400 mm
Serim masası eni	1800 - 2600 mm
Elektrik bilgileri	4 kW/220 V/50 Hz

Technical Specifications

Maximum spreading height with cutting device	250 mm
Maximum zigzag spreading height	220 mm
Maximum spreading height with tubular unit	200 mm
Maximum roll diameter	650 mm
Maximum roll weight	200 Kg
Maximum spreading speed (per minute)	100 m
Fabric width	1600 - 2400 mm
Table width	1800 - 2600 mm
Electrical power	4 kW/220 V/50 Hz

KUMAŞ GENİŞLİĞİ FABRIC WIDTH	A	B	C
1600	1800	2436	2561
1700	1900	2536	2661
1800	2000	2636	2761
1900	2100	2736	2861
2000	2200	2836	2961
2100	2300	2936	3061
2200	2400	3036	3161
2300	2500	3136	3261
2400	2600	3236	3361

MASTER Tam Otomatik Kumaş Serim Makinası Fully Automatic Fabric Spreading Machine

MT1



Sallama Aparatı - Otomatik Kesim Aparatı
Flat Fold Attachment - Automatic Cutting Device



Tüp Serim Aparatı
Tubular Unit



Zikzak Aparatı
Zigzag Equipment



Power System

200 KİLOYA KADAR HER TÜRLÜ KUMAŞIN TANSİYONSUZ KENAR HIZALI KOLAY SERİMİ

- ✓ Dokuma rulo ya da sallama kumaş (Full Likralı)
- ✓ Açık en örme rulo ya da sallama kumaş (Full Likralı)
- ✓ Tüp kumaş rulo ya da sallama (Full Likralı)

PLC KONTROLLÜ DOKUNMATİK EKРАН

- ✓ Öğrenmesi ve eğitimi kolay basitleştirilmiş grafik ekran
- ✓ 50 Farklı kumaş serim ayarının hafızaya alınıp, gerektiğinde tekrar serimi için hafızadan çağırılması
- ✓ Türkçe, İngilizce ve isteğe göre diğer yabancı dil seçenekleri

SİSTEM ÖZELLİKLERİ

- ✓ Değişen hız duyarlı elektronik kenar kontrol sistemi
- ✓ Emniyet sensörleri ile tehlike anında otomatik durma
- ✓ Merdiven kumaş serim özelliği
- ✓ Serim başlangıcı sırasında kumaşın otomatik merkezlenmesi
- ✓ İleri, geri gidişlerde farklı hız seçenekleri, zamandan tasarruf
- ✓ Kumaş bitti otomatik durma özelliği
- ✓ Kat sayıcı
- ✓ Programlanabilir kat uzunluğu ve ilave kumaş verme ayarı
- ✓ 4x4 tahrik sistemi

SPREADS ALL KINDS OF FABRIC ROLLS WEIGHTING UP 200 KGS (440LBS) WITHOUT TENSION AND EDGES ARE ALIGNED PERFECTLY

- ✓ Spreads woven fabrics in roll or flat-fold form (Low Lycra)
- ✓ Spreads knit fabrics in roll or flat-fold form (Low Lycra)
- ✓ Spreads tubular knit fabric in roll or flat-fold form (Low Lycra)

LCD TOUCH SCREEN DISPLAY WITH PLC UNIT

- ✓ Simplified display that is easy to learn and easy to train new operators
- ✓ Stores 50 different fabric set up files for quick retrieval to accelerate future spreading jobs
- ✓ Available in Turkish, English and any other foreign languages if requested

MULTI FUNCTION THROTTLE ENABLES THE OPERATOR TO CONTROL

- ✓ Threading/Rewinding of fabric
- ✓ Start/Stop of spreading with one hand

OPERATOR PLATFORM

- ✓ Allows operator to ride alongside the table

CRADLE FEED SYSTEM PROVIDES

- ✓ Tension-free spreading even difficult fabrics
- ✓ Electric cradle tilts for easy fabric roll loading/unloading
- ✓ Eliminates use of a fabric roll bar

SYSTEM FEATURES

- ✓ Electronic edge control responsive to variable speed
- ✓ Automatic stop with safety sensors in case of emergency
- ✓ Multi length spreading modes
- ✓ Automatic pre-centering of material beginning during threading
- ✓ Variable speed control at forward/backward turns «Save Time»
- ✓ No cloth stop function
- ✓ Ply counter
- ✓ Programmable lay length and end allowance settings
- ✓ Four-wheel drive with wheels

ATTACHMENTS

- ✓ Zigzag equipment
- ✓ Rear catcher
- ✓ Movable front catcher
- ✓ Flat-fold attachment
- ✓ Automatic cutting device
- ✓ Tubular unit (*optional)
- ✓ ML1 Master Lift